



Designation: B925 – 15 (Reapproved 2022)

Standard Practices for Production and Preparation of Powder Metallurgy (PM) Test Specimens¹

This standard is issued under the fixed designation B925; the number immediately following the designation indicates the year of original adoption or, in the case of revision, the year of last revision. A number in parentheses indicates the year of last reapproval. A superscript epsilon (ϵ) indicates an editorial change since the last revision or reapproval.

1. Scope*

1.1 These standard practices cover the specifications for those uniaxially compacted test specimens that are used in ASTM standards, the procedures for producing and preparing these test specimens, and reference the applicable standards.

1.2 Basic tool design and engineering information regarding the tooling that is required to compact the test specimens and machining blanks are contained in the annexes.

1.3 This standard is intended to be a comprehensive one-source document that can be referenced by ASTM test methods that utilize PM test specimens and in ASTM PM material specifications that contain the engineering data obtained from these test specimens.

1.4 These practices are not applicable to metal powder test specimens that are produced by other processes such as cold isostatic pressing (CIP), hot isostatic pressing (HIP), powder forging (PF) or metal injection molding (MIM). They do not pertain to cemented carbide materials.

1.5 Detailed information on PM presses, compacting tooling and sintering furnaces, their design, manufacture and use are not within the scope of these practices.

1.6 The values stated in inch-pound units are to be regarded as standard. The values given in parentheses are mathematical conversions to SI units that are provided for information only and are not considered standard.

1.7 *This standard may involve hazardous materials, operations, and equipment. This standard does not purport to address all of the safety concerns, if any, associated with its use. It is the responsibility of the user of this standard to establish appropriate safety, health, and environmental practices and determine the applicability of regulatory limitations prior to use.*

1.8 *This international standard was developed in accordance with internationally recognized principles on standard-*

ization established in the Decision on Principles for the Development of International Standards, Guides and Recommendations issued by the World Trade Organization Technical Barriers to Trade (TBT) Committee.

2. Referenced Documents

2.1 ASTM Standards:²

- [A34/A34M Practice for Sampling and Procurement Testing of Magnetic Materials](#)
- [A341/A341M Test Method for Direct Current Magnetic Properties of Soft Magnetic Materials Using D-C Permeameters and the Point by Point \(Ballistic\) Test Methods](#)
- [A596/A596M Test Method for Direct-Current Magnetic Properties of Materials Using the Point by Point \(Ballistic\) Method and Ring Specimens](#)
- [A773/A773M Test Method for Direct Current Magnetic Properties of Low Coercivity Magnetic Materials Using Hysteresigraphs](#)
- [A811 Specification for Soft Magnetic Iron Parts Fabricated by Powder Metallurgy Techniques](#)
- [A839 Specification for Iron-Phosphorus Powder Metallurgy Parts for Soft Magnetic Applications](#)
- [A904 Specification for 50 Nickel-50 Iron Powder Metallurgy Soft Magnetic Parts](#)
- [A927/A927M Test Method for Alternating-Current Magnetic Properties of Toroidal Core Specimens Using the Voltmeter-Ammeter-Wattmeter Method](#)
- [B215 Practices for Sampling Metal Powders](#)
- [B243 Terminology of Powder Metallurgy](#)
- [B312 Test Method for Green Strength of Specimens Compacted from Metal Powders](#)
- [B331 Test Method for Compressibility of Metal Powders in Uniaxial Compaction](#)
- [B438 Specification for Bronze-Base Powder Metallurgy \(PM\) Bearings \(Oil-Impregnated\)](#)
- [B439 Specification for Iron-Base Powder Metallurgy \(PM\) Bearings \(Oil-Impregnated\)](#)

¹ These practices are under the jurisdiction of ASTM Committee B09 on Metal Powders and Metal Powder Products and are the direct responsibility of Subcommittee B09.02 on Base Metal Powders.

Current edition approved March 1, 2022. Published March 2022. Originally approved in 2003. Last previous edition approved in 2015 as B925 – 15. DOI: 10.1520/B0925-15R22.

² For referenced ASTM standards, visit the ASTM website, www.astm.org, or contact ASTM Customer Service at service@astm.org. For *Annual Book of ASTM Standards* volume information, refer to the standard's Document Summary page on the ASTM website.

*A Summary of Changes section appears at the end of this standard

- [B528 Test Method for Transverse Rupture Strength of Powder Metallurgy \(PM\) Specimens](#)
- [B595 Specification for Materials for Aluminum Powder Metallurgy \(PM\) Structural Parts](#)
- [B610 Test Method for Measuring Dimensional Changes Associated with Processing Metal Powders Intended for Die Compaction](#)
- [B783 Specification for Materials for Ferrous Powder Metallurgy \(PM\) Structural Parts](#)
- [B817 Specification for Powder Metallurgy \(PM\) Titanium Alloy Structural Components \(Withdrawn 2013\)³](#)
- [B823 Specification for Materials for Copper Base Powder Metallurgy \(PM\) Structural Parts](#)
- [B853 Specification for Powder Metallurgy \(PM\) Boron Stainless Steel Structural Components](#)
- [B939 Test Method for Radial Crushing Strength, *K*, of Powder Metallurgy \(PM\) Bearings and Structural Materials](#)
- [B962 Test Methods for Density of Compacted or Sintered Powder Metallurgy \(PM\) Products Using Archimedes' Principle](#)
- [B963 Test Methods for Oil Content, Oil-Impregnation Efficiency, and Surface-Connected Porosity of Sintered Powder Metallurgy \(PM\) Products Using Archimedes' Principle](#)
- [E8 Test Methods for Tension Testing of Metallic Materials \[Metric\] E0008_E0008M](#)
- [E9 Test Methods of Compression Testing of Metallic Materials at Room Temperature](#)
- [E18 Test Methods for Rockwell Hardness of Metallic Materials](#)
- [E23 Test Methods for Notched Bar Impact Testing of Metallic Materials](#)
- [E228 Test Method for Linear Thermal Expansion of Solid Materials With a Push-Rod Dilatometer](#)
- [E1876 Test Method for Dynamic Young's Modulus, Shear Modulus, and Poisson's Ratio by Impulse Excitation of Vibration](#)

2.2 MPIF Standard:⁴

[Standard 56 Method for Determination of Rotating Beam Fatigue Endurance Limit in Powder Metallurgy Materials](#)

3. Terminology

3.1 *Definitions*—Definitions of powder metallurgy terms can be found in Terminology [B243](#). Additional descriptive information is available in the Related Materials section of Vol 02.05 of the *Annual Book of ASTM Standards*.

4. Summary of Practice

4.1 These practices describe the production, by pressing and sintering metal powders, and the preparation, by machining sintered blanks, of test specimens used to measure properties of metal powders and sintered materials.

³ The last approved version of this historical standard is referenced on www.astm.org.

⁴ Available from MPIF, 105 College Road East, Princeton, NJ 08540.

5. Significance and Use

5.1 Test specimens are used to determine the engineering properties of PM materials, for example, tensile strength, ductility, impact energy, etc.; property data that are essential to the successful use of PM material standards. Processing PM test specimens under production conditions is the most efficient method by which to obtain reliable PM material property data since in most cases it is impractical or impossible to cut test bars from sintered parts.

5.2 The performance characteristics of metal powders, for example, compressibility, green strength and dimensional changes associated with processing are evaluated using PM test specimens under controlled conditions. The data obtained are important to both metal powder producers and PM parts manufacturers.

5.3 PM test specimens play a significant role in industrial quality assurance programs. They are used to compare properties of a new lot of metal powder with an established lot in an acceptance test and are used in the part manufacturing process to establish and adjust production variables.

5.4 In those instances where it is required to present equivalent property data for a production lot of PM parts, standard test specimens compacted from the production powder mix to the same green density can be processed with the production PM parts and then tested to obtain this information.

5.5 Material property testing performed for industrial or academic research and development projects uses standard PM test specimens so the test results obtained can be compared with previous work or published data.

5.6 Powder metallurgy test specimens may have multiple uses. The dimensions and tolerances given in this standard are nominal in many cases. The user is cautioned to make certain that the dimensions of the test specimen are in agreement with the requirements of the specific test method to be used.

6. Powder Metallurgy Test Specimens

POWDER COMPRESSIBILITY TESTING

6.1 *Cylindrical Powder Compressibility Test Specimen:*

6.1.1 *Description and Use*—This solid cylindrical test specimen, see [Fig. 1](#), is produced by compacting a test portion of powder mix in laboratory powder metallurgy tooling similar to that shown in [Fig. A1.1](#) in the Annex. An alternative test specimen for measuring powder compressibility is the transverse rupture test specimen. These test specimens are not sintered. The compressibility of the metal powder mix or a compressibility curve showing the green density as a function of compacting pressure is determined according to the procedures in Test Method [B331](#).

6.1.2 *Applicable ASTM Standards:*

6.1.2.1 See Test Method [B331](#).

TRANSVERSE RUPTURE, DIMENSIONAL CHANGE AND GREEN STRENGTH TESTING

6.2 *Transverse Rupture Strength Test Specimen:*

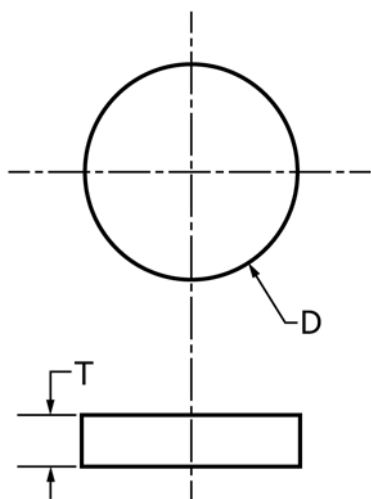

	Dimensions	
	in.	mm
D—Diameter	1.00	(25.4)
T—Compact thickness	0.280 ± 0.010	(7.11 ± 0.25)

FIG. 1 PM Cylindrical Powder Compressibility Test Specimen

6.2.1 *Description and Use*—The pressed-to-size transverse rupture test specimen, Fig. 2, is produced by compacting metal powder in tooling similar to that shown in Fig A1.2.

6.2.1.1 This rectangular test specimen has multiple uses in PM. Primarily, it is designed to determine the transverse rupture strength of sintered or heat treated compacts by breaking the test specimen as a simple beam in three-point loading following Test Method B528. But, it is also used to measure the dimensional changes of metal powder mixes due to pressing and sintering or other processing steps according to Test Method B610, and it is used in both a 0.250 and 0.500 in. (6.35 and 12.70 mm) thick version to determine green strength using the procedure in Test Method B312.

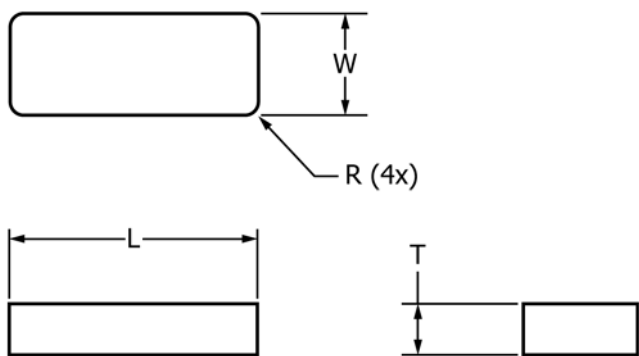

	Dimensions	
	in.	mm
W—Width	0.50	(12.7)
L—Length	1.25	(31.8)
R—Corner radius	0.01	(0.3)
T—Thickness (thin)	0.250 ± 0.005	(6.35 ± 0.13)
T—Thickness (thick)	0.500 ± 0.005	(12.70 ± 0.13)

NOTE 1—Thickness shall be parallel within 0.005 in. (0.13 mm).

FIG. 2 PM Transverse Rupture Strength Test Specimen

6.2.1.2 It is an acceptable alternative test specimen to the cylindrical compact to determine powder compressibility according to Test Method B331. The sintered or heat treated specimen may be used to generate data for the elastic constants. Young's Modulus is determined by impulse excitation of vibration and Poisson's ratio may then be calculated. This test specimen is also a convenient compact on which to measure macroindentation hardness after various processing steps.

6.2.2 *Applicable ASTM Standards:*

6.2.2.1 See the following Test Methods: B312, B331, B528, B610, E18, and E1876.

6.2.2.2 See the following PM Material Specifications: A811, A839, A904, B783, and B823.

RADIAL CRUSHING STRENGTH TESTING

6.3 *Radial Crushing Strength Test Specimen:*

6.3.1 *Description and Use*—The radial crushing strength test specimen shown in Fig. 3 is compacted to size in tooling (Fig. A2.3) suitable for the production of a thin-walled hollow cylinder within the range of the dimensions listed. The testing procedure involves the application of a compressive force perpendicular to the central axis of the test cylinder and calculating the radial crushing strength from the breaking load and test specimen dimensions. Radial crushing strength is the material property that is used to quantify the mechanical strength of sintered metal bearings, (oil-impregnated).

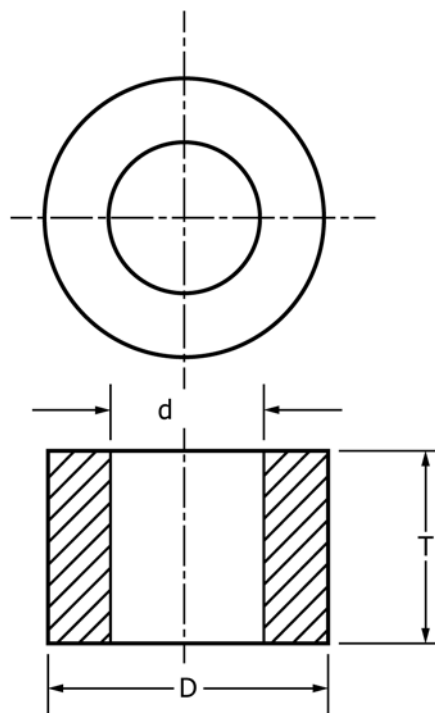

	Dimensions	
	in.	mm
D—Outside diameter	0.80 to 2.00	(20 to 51)
d—Inside diameter	0.50 to 1.00	(13 to 25)
T—Thickness	0.25 to 1.00	(6 to 25)

NOTE 1—Wall thickness (D-d) shall be less than D/3.

FIG. 3 PM Radial Crushing Strength Test Specimen